

Displays & Touch Screens

ULTRATRONIK Vertriebs GmbH

Dornierstraße 9
82205 Gilching

T +49 8105 77839-0
F +49 8105 77839-850

www.ultratronic-distribution.de
displays@ultratronic.de

Error and omissions excepted
Observe notice of protected rights in accordance to DIN34 / ISO16016





DATA IMAGE CORPORATION

TFT Module Specification

Preliminary

ITEM NO.: FG0700GDDSSWBG01

Table of Contents

- 1. COVER & CONTENTS 1
- 2. RECORD OF REVISION 2
- 3. APPLICATION..... 3
- 4. GENERAL SPECIFICATIONS 3
- 5. ABSOLUTE MAXIMUM RATINGS 3
- 6. ELECTRICAL CHARACTERISTICS 3
- 7. INTERFACE SPECIFICATIONS 4
- 8. OPTICAL CHARACTERISTIC 8
- 9. PIN CONNECTIONS 11
- 10. BLOCK DIAGRAM 13
- 11. QUALITY ASSURANCE 14
- 12. LCM PRODUCT LABEL DEFINE 18
- 13. PRECAUTIONS IN USE LCM 20
- 14. OUTLINE DRAWING 21
- 15. PACKAGE INFORMATION..... 22

Customer Companies	QA Approval	QA Check	R&D Approval	R&D Check
	<i>pretty</i>	<i>Seven</i>	<i>Jack</i>	<i>Lisa</i>
Approved by	Version:	Issued Date:	Sheet Code:	Total Pages:
	1	22/DEC/15'		22

3. APPLICATION

DVD player, Car TV, UMPC, POS

4. GENERAL SPECIFICATIONS

Parameter	Specifications	Unit
Screen Size	7 (diagonal)	inch
Display Format	800(H) x (R,G,B) x 480(V)	dot
Active Area	152.4(H) x 91.44(V)	mm
Pixel Pitch	0.1905(W) x 0.1905(H)	mm
Pixel Configuration	Stripe	
Outline Dimension	165(W) x 106.4(H) x 6.7 (D)	mm
Surface treatment	Clear	
Back-light	LED	
Display mode	Normally white	
Weight	140	g
View Angle direction	All	
Our components and processes are compliant to RoHS standard		

5. ABSOLUTE MAXIMUM RATINGS

GND=0V

Parameter	Symbol	MIN.	MAX.	Unit	Remark
Power supply voltage	V _{CC}	-0.3	7	V	Ta=25°C
Logic input voltage	V _I	-0.3	V _{CC} +0.3	V	
Operating temperature	T _{op}	-20	70	°C	Module surface*
Storage temperature	T _{st}	-30	+80	°C	-
Humidity	Operation	20%~90% relative humidity			Ta<=38°C
	Non Operation	5%~90% relative humidity			Ta<=38°C

6. ELECTRICAL CHARACTERISTICS

GND=0V, f_H=31.5KHz, f_V=60Hz, f_{CLK}=33.26MHz, Ta=25°C

Parameter	Symbol	MIN.	Typ.	MAX.	Unit	Remark
Power Supply voltage	V _{CC}	3.0	3.3	3.6	V	
Power Supply Current	I _{CC}		150	200	mA	V _{CC} =3.3V
Power Supply voltage for LED	V _{DD}	3.0	3.3	5.5	V	
Power Supply Current for LED	I _{DD}	-	650	850	mA	V _{DD} =3.3V
		-	400	550	mA	V _{DD} =5.0V
Ripple voltage	V _{RF}	-	-	100	mV _{P-P}	
"H" level logical input voltage	V _{IH}	0.7V _{CC}	-	V _{CC}	V	
"L" level logical input voltage	V _{IL}	0	-	0.3V _{CC}	V	
ADJ frequency		19K	20K	21K	Hz	
ADJ input voltage	V _{IH}	3.0	-	3.3	V	
	V _{IL}	0	-	0.3	V	
LED life time		20,000	30,000	-	Hr	

7. INPUT SIGNAL CHARACTERISTICS

7.1 AC Characteristics

7.1.1 AC Electrical Characteristics

Parameter	Symbol	MIN.	TYP.	MAX.	Unit
Data setup time	T_{dsu}	6	-	-	ns
Data hold time	T_{dhd}	6	-	-	ns
DE setup time	T_{esu}	6	-	-	ns

7.1.2 Resolution : 800x480

ITEM	SYMBOL	MIN.	TYP.	MAX.	UNIT
CLK frequency	F_{CPH}	-	33.26	-	MHz
CLK period	T_{CPH}	-	30.06	-	ns
CLK pulse duty	T_{CWH}	40	50	60	%
DE period	$T_{DEH}+T_{DEL}$	1000	1056	1200	T_{CPH}
DE pulse width	T_{DH}	-	800	-	T_{CPH}
DE frame blanking	T_{HS}	10	45	110	$T_{DEH}+T_{DEL}$
DE frame width	T_{EP}	-	480	-	$T_{DEH}+T_{DEL}$

ITEM	SYMBOL	MIN.	TYP.	MAX.	UNIT
OEV pulse width	T_{OEV}	-	150	-	T_{CPH}
CKV pulse width	T_{CKV}	-	133	-	T_{CPH}
DE(internal)-STV time	T_1	-	4	-	T_{CPH}
DE(internal)-CKV time	T_2	-	40	-	T_{CPH}
DE(internal)-OEV time	T_3	-	23	-	T_{CPH}
DE(internal)-POL time	T_4	-	157	-	T_{CPH}
STV pulse width	-	-	1	-	T_H

7.2 Timing Controller Timing Chart
7.2.1 Clock and Data input waveforms

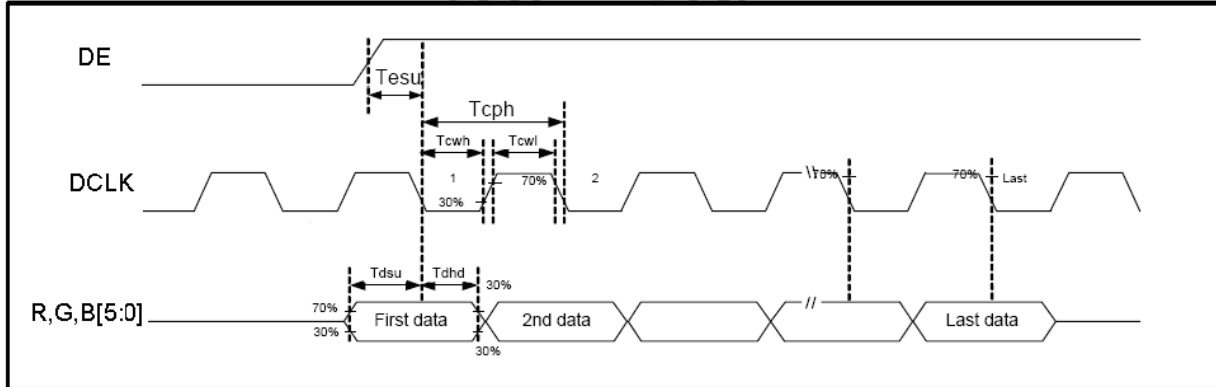

Figure 1 Clock and Data input waveforms.

7.2.2 DE Mode Data Format

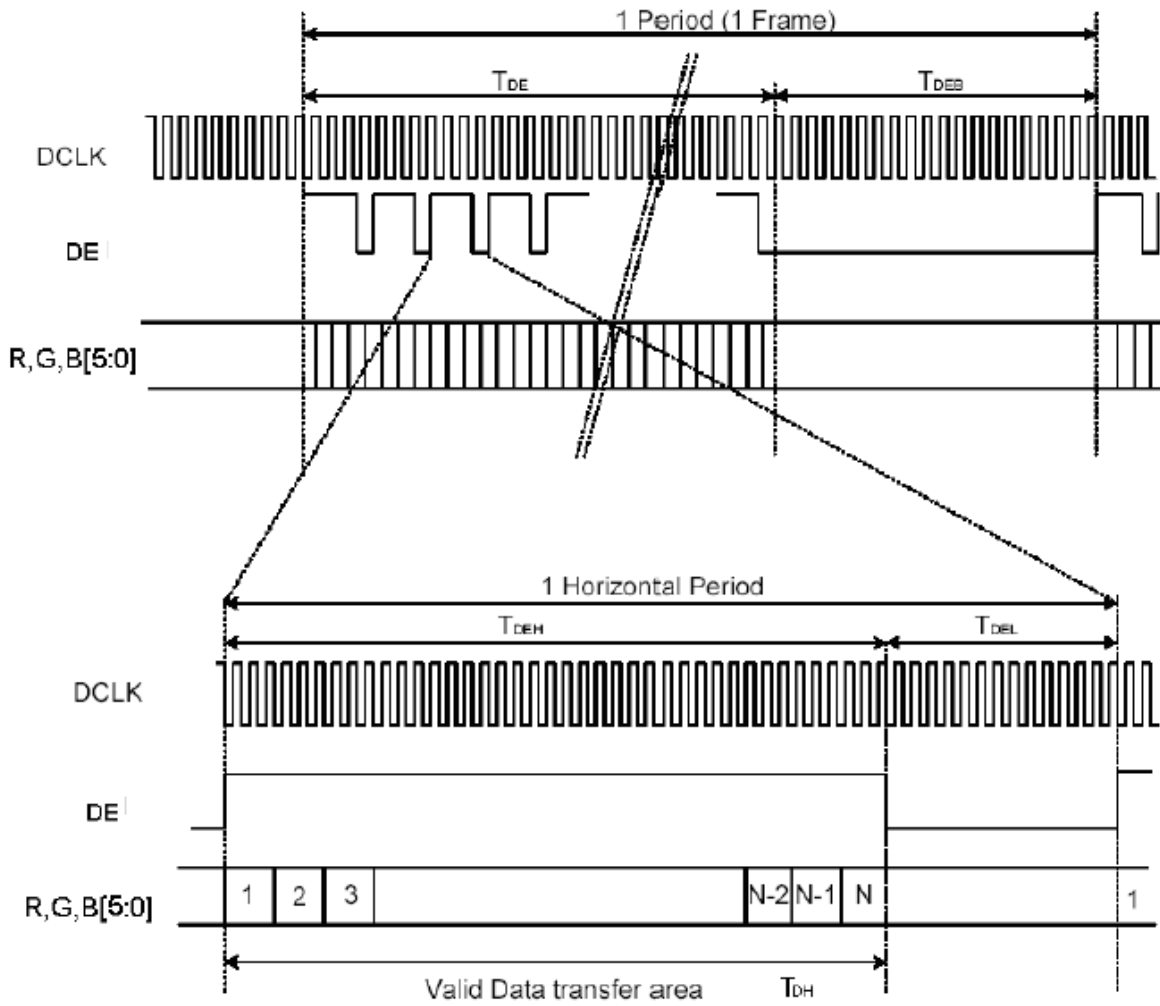

Figure 2 DE Mode Data Format

7.3 Color Data Input Assignment

		Data Signal																	
		Red						Green						Blue					
Color		R5	R4	R3	R2	R1	R0	G5	G4	G3	G2	G1	G0	B5	B4	B3	B2	B1	B0
Basic Colors	Black	0	0	0	0	0	0	0	0	0	0	0	0	0	0	0	0	0	0
	Red	1	1	1	1	1	1	0	0	0	0	0	0	0	0	0	0	0	0
	Green	0	0	0	0	0	0	1	1	1	1	1	1	0	0	0	0	0	0
	Blue	0	0	0	0	0	0	0	0	0	0	0	0	1	1	1	1	1	1
	Cyan	0	0	0	0	0	0	1	1	1	1	1	1	1	1	1	1	1	1
	Magenta	1	1	1	1	1	1	0	0	0	0	0	0	1	1	1	1	1	1
	Yellow	1	1	1	1	1	1	1	1	1	1	1	1	0	0	0	0	0	0
	White	1	1	1	1	1	1	1	1	1	1	1	1	1	1	1	1	1	1
Gray Scale of Red	Red(0) / Dark	0	0	0	0	0	0	0	0	0	0	0	0	0	0	0	0	0	0
	Red(1)	0	0	0	0	0	1	0	0	0	0	0	0	0	0	0	0	0	0
	Red(2)	0	0	0	0	1	0	0	0	0	0	0	0	0	0	0	0	0	0
	:	:	:	:	:	:	:	:	:	:	:	:	:	:	:	:	:	:	:
	:	:	:	:	:	:	:	:	:	:	:	:	:	:	:	:	:	:	:
	Red(61)	1	1	1	1	0	1	0	0	0	0	0	0	0	0	0	0	0	0
	Red(62)	1	1	1	1	1	0	0	0	0	0	0	0	0	0	0	0	0	0
	Red(63)	1	1	1	1	1	1	0	0	0	0	0	0	0	0	0	0	0	0
Gray Scale of Green	Green(0) / Dark	0	0	0	0	0	0	0	0	0	0	0	0	0	0	0	0	0	0
	Green(1)	0	0	0	0	0	0	0	0	0	0	0	1	0	0	0	0	0	0
	Green(2)	0	0	0	0	0	0	0	0	0	0	1	0	0	0	0	0	0	0
	:	:	:	:	:	:	:	:	:	:	:	:	:	:	:	:	:	:	:
	:	:	:	:	:	:	:	:	:	:	:	:	:	:	:	:	:	:	:
	Green(61)	0	0	0	0	0	0	1	1	1	1	0	1	0	0	0	0	0	0
	Green(62)	0	0	0	0	0	0	1	1	1	1	1	0	0	0	0	0	0	0
	Green(63)	0	0	0	0	0	0	1	1	1	1	1	1	0	0	0	0	0	0
Gray Scale of Blue	Blue(0) / Dark	0	0	0	0	0	0	0	0	0	0	0	0	0	0	0	0	0	0
	Blue (1)	0	0	0	0	0	0	0	0	0	0	0	0	0	0	0	0	0	1
	Blue (2)	0	0	0	0	0	0	0	0	0	0	0	0	0	0	0	0	1	0
	:	:	:	:	:	:	:	:	:	:	:	:	:	:	:	:	:	:	:
	:	:	:	:	:	:	:	:	:	:	:	:	:	:	:	:	:	:	:
	Blue (61)	0	0	0	0	0	0	0	0	0	0	0	0	1	1	1	1	0	1
	Blue (62)	0	0	0	0	0	0	0	0	0	0	0	0	1	1	1	1	1	0
	Blue (63)	0	0	0	0	0	0	0	0	0	0	0	0	1	1	1	1	1	1

8. OPTICAL CHARACTERISTIC

Parameter	Symbol	Condition	MIN.	TYP.	MAX.	Unit	Remarks	
Viewing Angle	Horizontal	θ_{x+}	60	70	--	deg	Note 1,4	
		θ_{x-}	60	70	--			
	Vertical	θ_{y+}	40	50	--			
		θ_{y-}	50	60	--			
Contrast Ratio		CR	at optimized viewing angle	500	600	--	Note 1,3	
Response time	Rise	Tr	Center	--	5	10	ms	Note 1,6
	Fall	Tf	$\theta_x=\theta_y=0^\circ$	--	15	20	ms	
Uniformity		B-uni	$\theta_x=\theta_y=0^\circ$	70	80	--	%	Note1,5
Brightness		L	$\theta_x=\theta_y=0^\circ$	500	625	--	cd/m ²	Note 1,2
Chromaticity	x_W	Center $\theta_x=\theta_y=0^\circ$	0.268	0.318	0.368		Note 1,7	
	y_W		0.289	0.339	0.389			
	x_R		0.525	0.575	0.625			
	y_R		0.310	0.360	0.410			
	x_G		0.281	0.331	0.381			
	y_G		0.521	0.571	0.621			
	x_B		0.099	0.149	0.199			
	y_B		0.088	0.138	0.188			
Image sticking		tis	2 hours	--	--	2	Sec	Note 8

The following optical specifications shall be measured in a darkroom or equivalent state (ambient luminance ≤ 1 lux, and at room temperature).

The operation temperature is $25^\circ\text{C} \pm 2^\circ\text{C}$ and LED Backlight Current $\text{IDD}=250\text{mA}$.

The measurement method is shown in Note1.

Note1: The method of optical measurement:

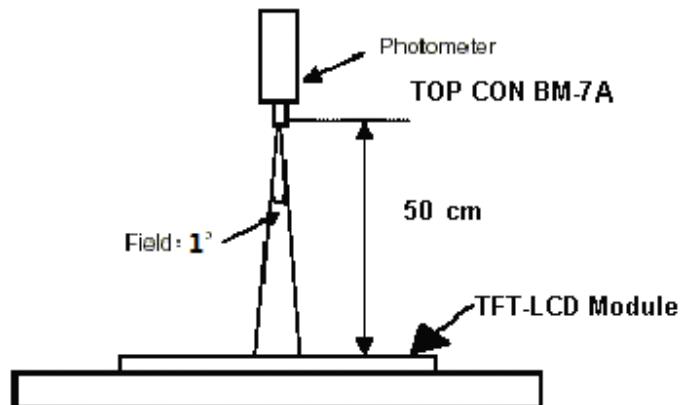

Note2: Measured at the center area of the panel and at the viewing angle of the $\theta_x = \theta_y = 0^\circ$

Note3: Definition of Contrast Ratio (CR):

$$CR = \frac{\text{Luminance with all pixels in white state}}{\text{Luminance with all pixels in Black state}}$$

Note4: Definition of Viewing Angle

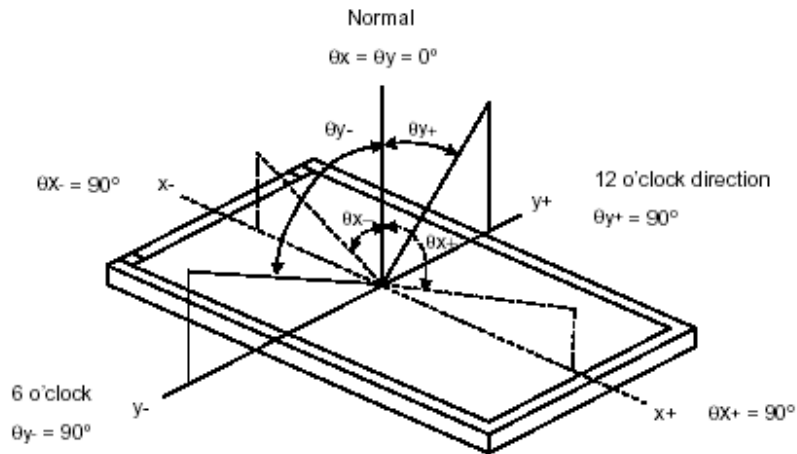

Note 5: Definition of Brightness Uniformity (B-uni):

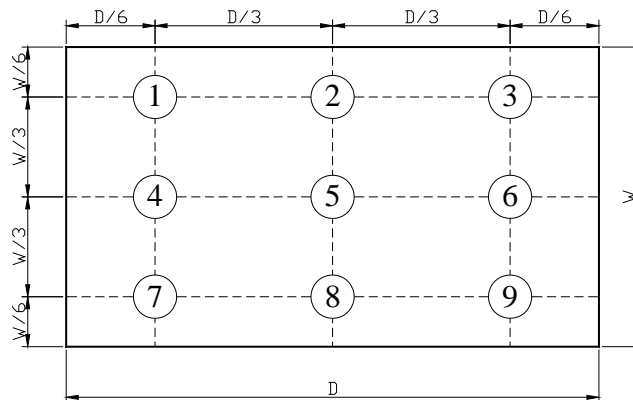

$$B\text{-uni} = \frac{\text{Minimum luminance of 9 points}}{\text{Maximum luminance of 9 points}} \quad (\text{Note 5}).$$

Note6: Definition of Response Time:

The Response Time is set initially by defining the “Rising Time (Tr)” and the “Falling Time (Tf)” respectively. Tr and Tf are defined as following figure.

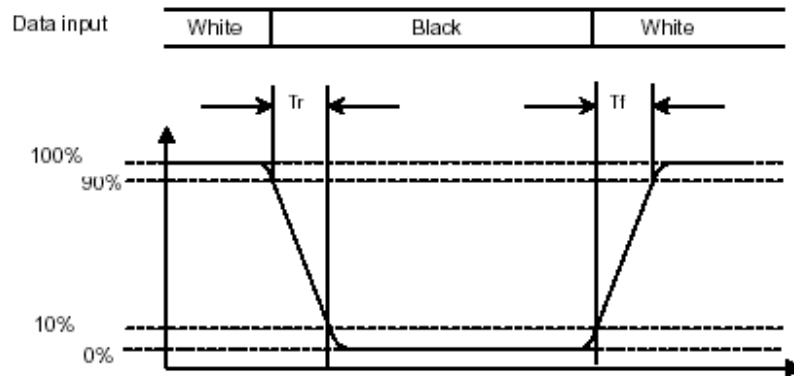

Note 7: Definition of Chromaticity:

The color coordinates (x_w, y_w) , (x_r, y_r) , (x_g, y_g) , and (x_b, y_b) are obtained with all pixels in the viewing field at white, red, green, and blue states, respectively.

Note 8: Definition of Image sticking (tis):

Continuously display the test pattern shown in the figure below for 2 hours. Then display a completely white screen.

The previous image shall not persist more than 2 sec at 25 °C

Image sticking pattern

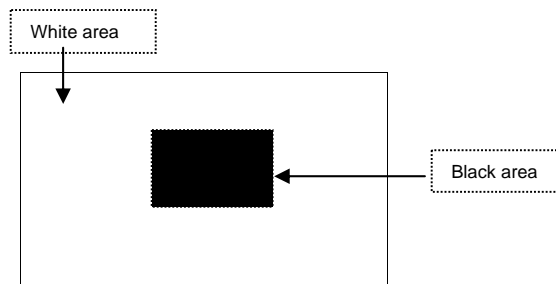

9. PIN CONNECTIONS

Pin NO.	SYMBOL	DESCRIPTION
1	V _{SS}	Power Ground
2	V _{SS}	Power Ground
3	ADJ	Brightness control for LED B/L
4	VDD	Power Supply for LED Driver
5	VDD	Power Supply for LED Driver
6	VDD	Power Supply for LED Driver
7	V _{CC}	Power Supply for Digital Circuit
8	V _{CC}	Power Supply for Digital Circuit
9	DE	Data Enable
10	V _{SS}	Power Ground
11	V _{SS}	Power Ground
12	V _{SS}	Power Ground
13	B5	Blue Data 5 (MSB)
14	B4	Blue Data 4
15	B3	Blue Data 3
16	V _{SS}	Power Ground
17	B2	Blue Data 2
18	B1	Blue Data 1
19	B0	Blue Data 0 (LSB)
20	V _{SS}	Power Ground
21	G5	Green Data 5 (MSB)
22	G4	Green Data 4
23	G3	Green Data 3
24	V _{SS}	Power Ground
25	G2	Green Data 2
26	G1	Green Data 1
27	G0	Green Data 0 (LSB)
28	V _{SS}	Power Ground
29	R5	Red Data 5 (MSB)
30	R4	Red Data 4
31	R3	Red Data 3
32	V _{SS}	Power Ground
33	R2	Red Data 2
34	R1	Red Data 1
35	R0	Red Data 0
36	V _{SS}	Power Ground
37	V _{SS}	Power Ground
38	DCLK	Clock Signals ; Latch Data at the Falling Edge
39	V _{SS}	Power Ground
40	V _{SS}	Power Ground

Remarks :

- 1) ADJ is brightness control Pin. The larger of the pulse duty is, the higher of the brightness.
- 2) ADJ signal is 0~3.3V.Operation frequency is 20KHz
- 3) VSS PIN must be grounding, can not be floating.

Remarks:

Power Signal sequence:

- $t1 \leq 10\text{ms}$; $1 \text{ sec} \leq t5$
- $50\text{ms} \leq t2$; $200\text{ms} \leq t6$
- $0 < t3 \leq 50\text{ms}$; $200\text{ms} \leq t7$
- $0 < t4 \leq 10\text{ms}$

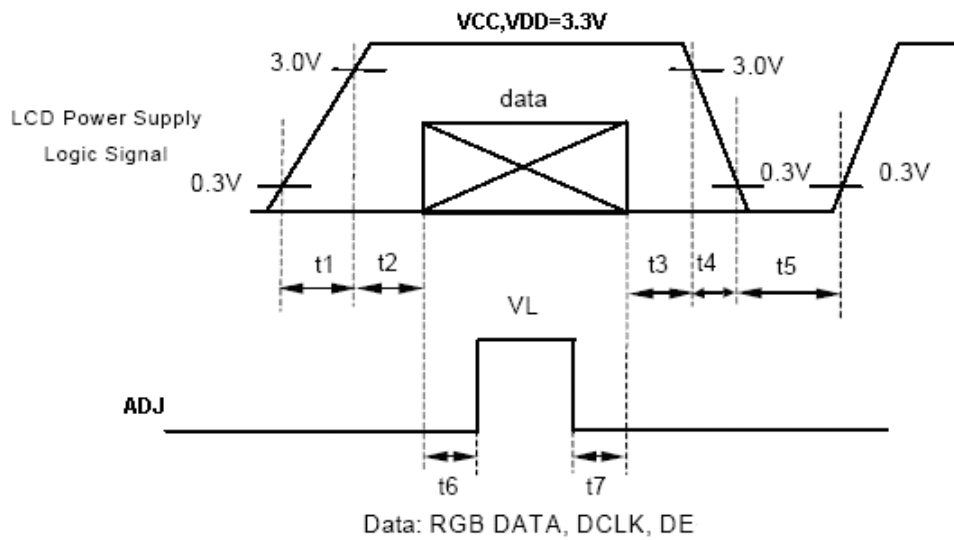

VCC,VDD -dip condition:

- (1) $2.7\text{V} \leq VCC, VDD \leq 3.0\text{V}$: $t_d \leq 10 \text{ ms}$
- (2) $VCC, VDD > 3.0\text{V}$: VCC,VDD -dip condition should be the same with VCC,VDD-turn-on condition.

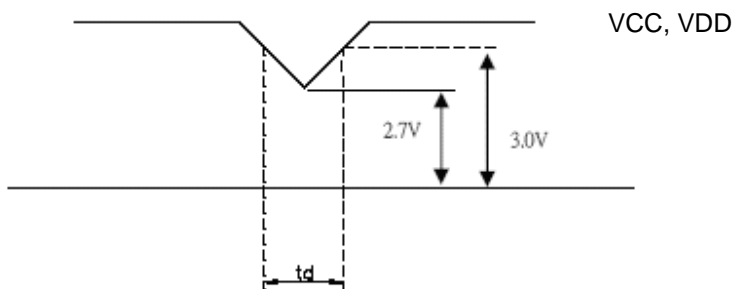

10. BLOCK DIAGRAM

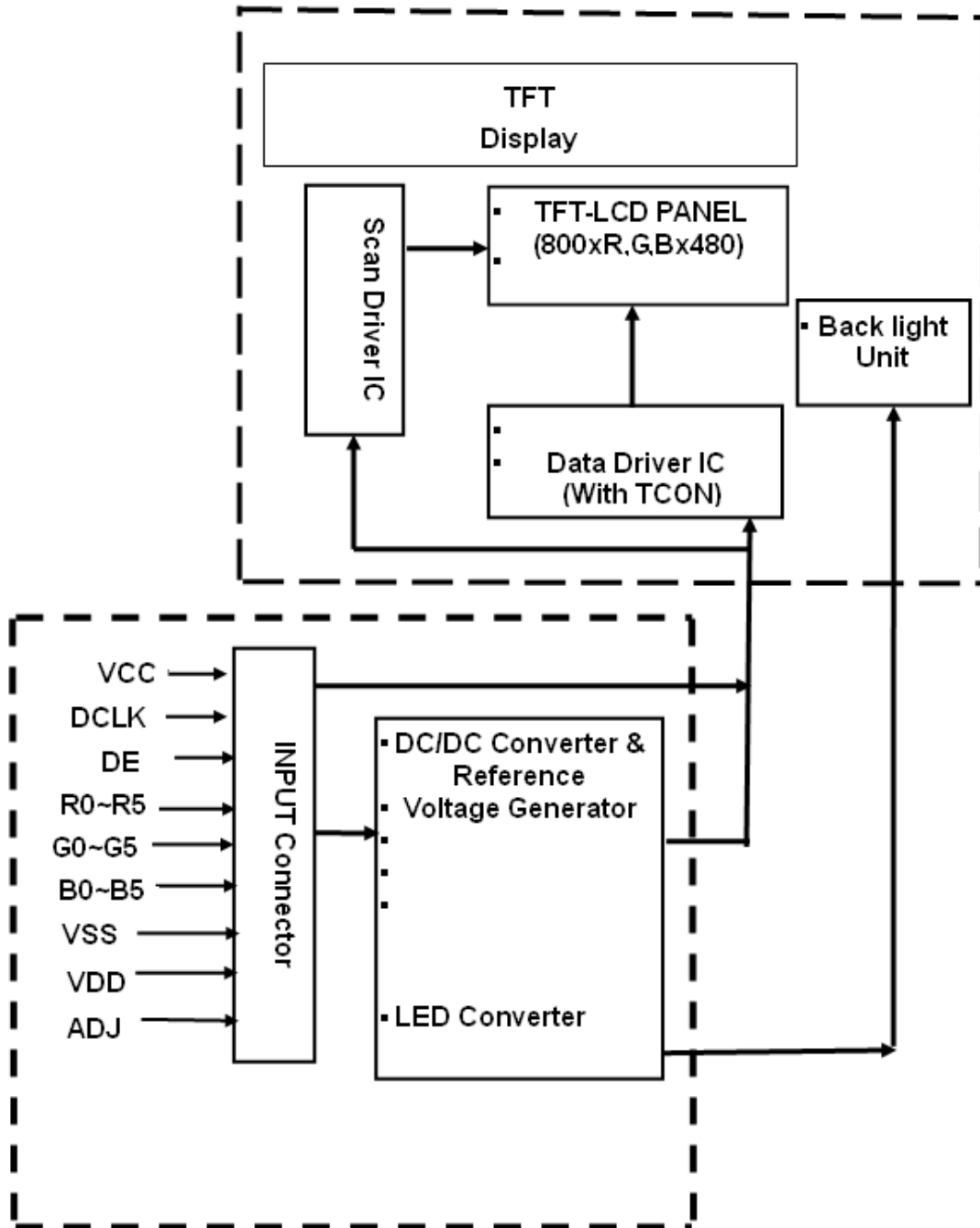

11. QUALITY ASSURANCE

11.1 Test Condition

11.1.1 Temperature and Humidity(Ambient Temperature)

Temperature : $25 \pm 5^{\circ}\text{C}$

Humidity : $65 \pm 5\%$

11.1.2 Operation

Unless specified otherwise, test will be conducted under function state.

11.1.3 Container

Unless specified otherwise, vibration test will be conducted to the product itself without putting it in a container.

11.1.4 Test Frequency

In case of related to deterioration such as shock test. It will be conducted only once.

11.1.5 Test Method

Reliability Test Item & Level		Test Level	Remark
No.	Test Item		
1.	High Temperature Storage Test	T= 80°C ,240hrs	IEC68-2-2
2.	Low Temperature Storage Test	T= -30°C ,240hrs	IEC68-2-1
3.	High Temperature Operation Test	T= 70°C , 240hrs	IEC68-2-1
4.	Low Temperature Operation Test	T= -20°C , 240hrs	IEC68-2-2
5.	High Temperature and High Humidity Operation Test	T= 60°C ,90%RH,240hrs	IEC68-2-3
6.	Thermal Cycling Test (No operation)	$-30^{\circ}\text{C} \rightarrow +25^{\circ}\text{C} \rightarrow +80^{\circ}\text{C}$,100 Cycles 30 min 5min 30 min	IEC68-2-14
7.	Vibration Test	Frequency:10~55HZ Amplitude:1.5mm Sweep time:11min Test period:6Cycles for each direction of X,Y,Z	IEC68-2-6
8	Shock Test	100G, 6ms Direction : $\pm X, \pm Y, \pm Z$ Cycle : 3 times	IEC68-2-27
9	Drop Test	Height:60cm 1 conner,3edges,6surfaces	IEC68-2-32
10.	ESD test	State: operating Location: LCM/TP surface Condition:150pf 330 Ω Contact +/- 8kV Air +/-15kV Criteria: Class C	IEC61000-4-2

11.2 APPEARANCE SPECIFICATION

11.2.1 Inspection conditions

11.2.1.1 Inspection Distance : 35 ± 5 cm

11.2.1.2 View Angle :

- (1) Inspection under operating condition : $\pm 5^\circ$
- (2) Inspection under non-operating condition : $\pm 45^\circ$

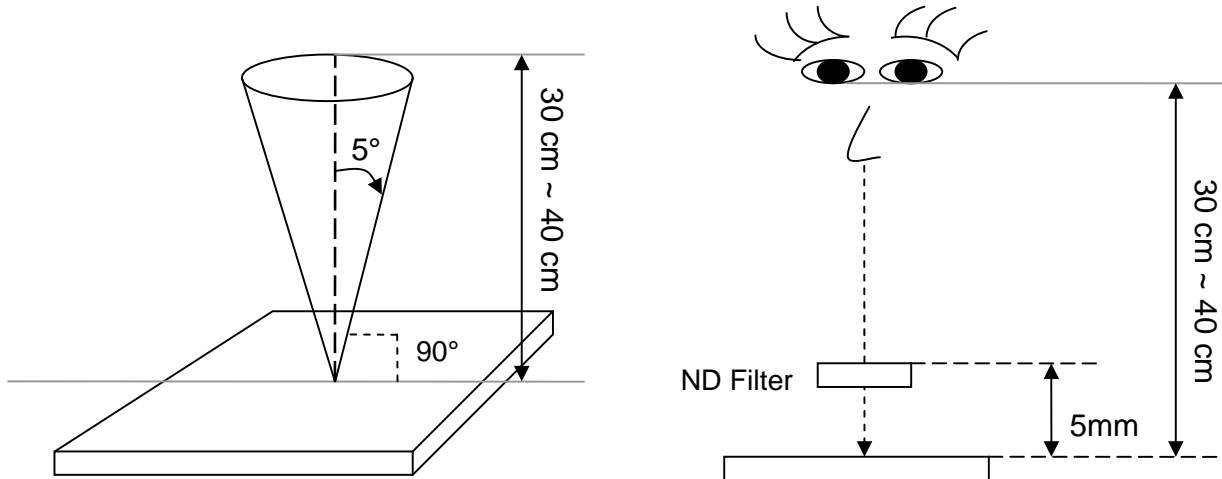

11.2.1.3 Environment conditions :

Ambient Temperature :		$25 \pm 5^\circ\text{C}$
Ambient Humidity :		$65 \pm 5\%$
Ambient Illumination	Cosmetic Inspection	More than 600lux
	Functional Inspection	300 ~ 800lux

11.2.2 Definition of applicable Zones

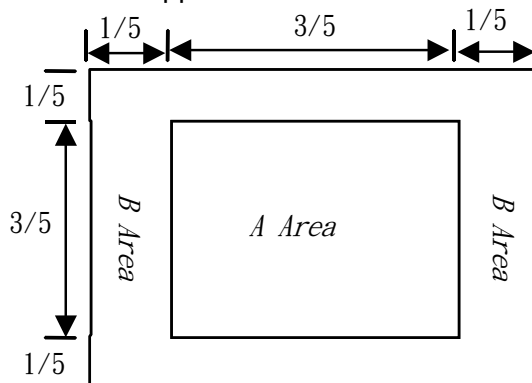

11.2.3 Inspection Parameters

No.	Parameter	Criteria																		
1	Operating	Display function: No Display malfunction (Major)																		
		Contrast ratio (Black, White): Does not meet specified range in the spec. (Major) (Note:3)																		
		Line Defect: No obvious Vertical and Horizontal line defect in bright, dark and colored. (Major) (Note:1)																		
		Point Defect (Red, green, blue, dark): Active area ≤ 8 dots (Minor)(Note:1)																		
		<table border="1"> <thead> <tr> <th>Item</th> <th>Acceptable number</th> <th>Total</th> <th>Class Of Defects</th> <th>AQL Level</th> </tr> </thead> <tbody> <tr> <td>Bright</td> <td>4</td> <td rowspan="2">8</td> <td rowspan="4">Minor</td> <td rowspan="4">1.5</td> </tr> <tr> <td>Dark</td> <td>4</td> </tr> <tr> <td>Adjacent Bright</td> <td>1</td> <td>1</td> </tr> <tr> <td>Adjacent Dark</td> <td>1</td> <td>1</td> </tr> </tbody> </table>	Item	Acceptable number	Total	Class Of Defects	AQL Level	Bright	4	8	Minor	1.5	Dark	4	Adjacent Bright	1	1	Adjacent Dark	1	1
		Item	Acceptable number	Total	Class Of Defects	AQL Level														
		Bright	4	8	Minor	1.5														
		Dark	4																	
		Adjacent Bright	1	1																
		Adjacent Dark	1	1																
Non-uniformity: Visible through 2%ND filter white, R, G, B and gray 50%pattern. (Minor)																				
Foreign material in Black or White spots shape ($W > 1/4L$) (Note: 5)																				
<table border="1"> <thead> <tr> <th>Dimension</th> <th>Acceptable number</th> <th>Class Of Defects</th> <th>AQL Level</th> </tr> </thead> <tbody> <tr> <td>$D \leq 0.3$</td> <td>*</td> <td rowspan="3">Minor</td> <td rowspan="3">1.5</td> </tr> <tr> <td>$0.3 < D \leq 0.5$</td> <td>4</td> </tr> <tr> <td>$D > 0.5$</td> <td>0</td> </tr> </tbody> </table>	Dimension	Acceptable number	Class Of Defects	AQL Level	$D \leq 0.3$	*	Minor	1.5	$0.3 < D \leq 0.5$	4	$D > 0.5$	0								
Dimension	Acceptable number	Class Of Defects	AQL Level																	
$D \leq 0.3$	*	Minor	1.5																	
$0.3 < D \leq 0.5$	4																			
$D > 0.5$	0																			
$D = (\text{Long} + \text{Short}) / 2$ * : Disregard																				
Foreign Material in Line or spiral shape ($W \leq 1/4L$) (Note: 4)																				
<table border="1"> <thead> <tr> <th>Dimension</th> <th>Acceptable number</th> <th>Class Of Defects</th> <th>AQL Level</th> </tr> </thead> <tbody> <tr> <td>$W > 0.1\text{mm}, L > 5\text{mm}$</td> <td>0</td> <td rowspan="3">Minor</td> <td rowspan="3">1.5</td> </tr> <tr> <td>$L \leq 5\text{mm}, 0.07\text{mm} < W \leq 0.1\text{mm}$</td> <td>4</td> </tr> <tr> <td>$L \leq 5\text{mm}, W < 0.07\text{mm}$</td> <td>*</td> </tr> </tbody> </table>	Dimension	Acceptable number	Class Of Defects	AQL Level	$W > 0.1\text{mm}, L > 5\text{mm}$	0	Minor	1.5	$L \leq 5\text{mm}, 0.07\text{mm} < W \leq 0.1\text{mm}$	4	$L \leq 5\text{mm}, W < 0.07\text{mm}$	*								
Dimension	Acceptable number	Class Of Defects	AQL Level																	
$W > 0.1\text{mm}, L > 5\text{mm}$	0	Minor	1.5																	
$L \leq 5\text{mm}, 0.07\text{mm} < W \leq 0.1\text{mm}$	4																			
$L \leq 5\text{mm}, W < 0.07\text{mm}$	*																			
L : Length W : Width * : Disregard																				
2	External Inspection (non-operating)	Dimension: Outline (Major)																		
		Bezel appearance: uneven (Minor)																		
		Scratch on the Polarize & Touch Panel : (Note:2)																		
		<table border="1"> <thead> <tr> <th>Dimension</th> <th>Acceptable number</th> <th>Class Of Defects</th> <th>AQL Level</th> </tr> </thead> <tbody> <tr> <td>$W > 0.1\text{mm}, L > 5\text{mm}$</td> <td>0</td> <td rowspan="3">Minor</td> <td rowspan="3">1.5</td> </tr> <tr> <td>$L \leq 5\text{mm}, 0.07\text{mm} < W \leq 0.1\text{mm}$</td> <td>4</td> </tr> <tr> <td>$L \leq 5\text{mm}, W < 0.07\text{mm}$</td> <td>*</td> </tr> </tbody> </table>	Dimension	Acceptable number	Class Of Defects	AQL Level	$W > 0.1\text{mm}, L > 5\text{mm}$	0	Minor	1.5	$L \leq 5\text{mm}, 0.07\text{mm} < W \leq 0.1\text{mm}$	4	$L \leq 5\text{mm}, W < 0.07\text{mm}$	*						
		Dimension	Acceptable number	Class Of Defects	AQL Level															
$W > 0.1\text{mm}, L > 5\text{mm}$	0	Minor	1.5																	
$L \leq 5\text{mm}, 0.07\text{mm} < W \leq 0.1\text{mm}$	4																			
$L \leq 5\text{mm}, W < 0.07\text{mm}$	*																			
L : Length W : Width * : Disregard																				

		Dent and spots shape on the polarize (Note:2): (Note: 5)			
		Dimension	Acceptable number	Class Of Defects	AQL Level
		$D \leq 0.3$	*	Minor	1.5
		$0.3 < D \leq 0.5$	4		
		$D > 0.5$	0		
		$D = (\text{Long} + \text{Short}) / 2$ * : Disregard			

Class of defects		AQL	Definition			
			<table border="1"> <tr> <td>Major</td> <td>AQL 0.65</td> <td>It is a defect that is likely to result in failure or to reduce materially the usability of the product for the intended function.</td> </tr> <tr> <td>Minor</td> <td>AQL 1.5</td> <td>It is a defect that will not result in functioning problem with deviation classified.</td> </tr> </table>	Major	AQL 0.65	It is a defect that is likely to result in failure or to reduce materially the usability of the product for the intended function.
Major	AQL 0.65	It is a defect that is likely to result in failure or to reduce materially the usability of the product for the intended function.				
Minor	AQL 1.5	It is a defect that will not result in functioning problem with deviation classified.				

Note:1.(a)Bright point defect is defined as point defect of R,G,B with area $>1/2$ pixel respectively

(b)Dark point defect is defined as visible in full white pattern.

(c)The point defect must under 2% ND Filter visible .

Note:2 The external inspection should be conducted at the distance 30 ± 5 cm between the eyes of inspector and the panel .

Note:3 Luminance measurement for contrast ratio is at the distance 50 ± 5 cm between the detective head and the panel with ambient luminance less than 1 lux. Contrast ratio is obtained at optimum view angle.

Note:4 W-Width in mm , L-length of Max.(L1,L2) in mm.

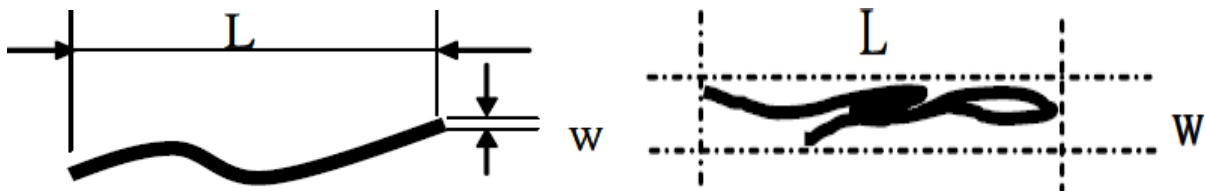

Note:5 Spot Foreign Material ($W \geq L/4$)

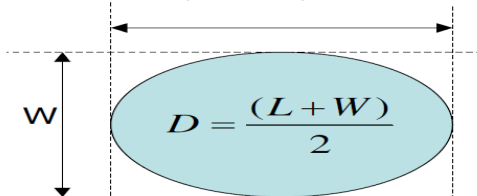

11.3 Sampling Condition

Unless otherwise agree in written, the sampling inspection shall be applied to the incoming inspection of customer.

Lot size: Quantity of shipment lot per model.

Sampling type: normal inspection, single sampling

Sampling table: ISO2859

Inspection level: Level II

12. LCM PRODUCT LABEL DEFINE

Product Label style:

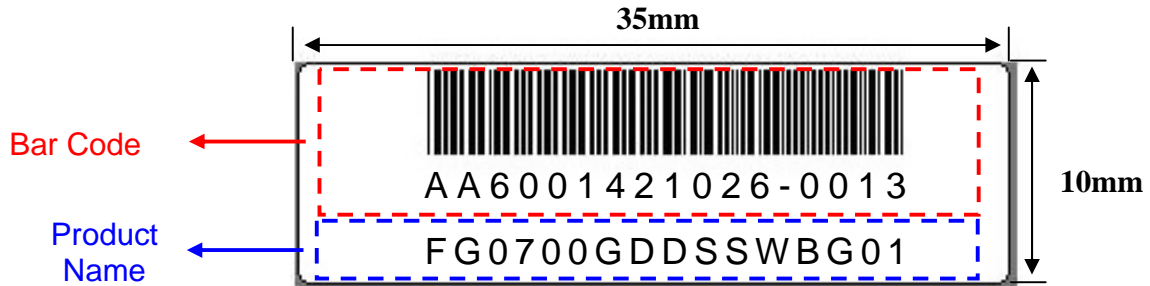

BarCode Define:

A A 6 0014 2 10 26-0013

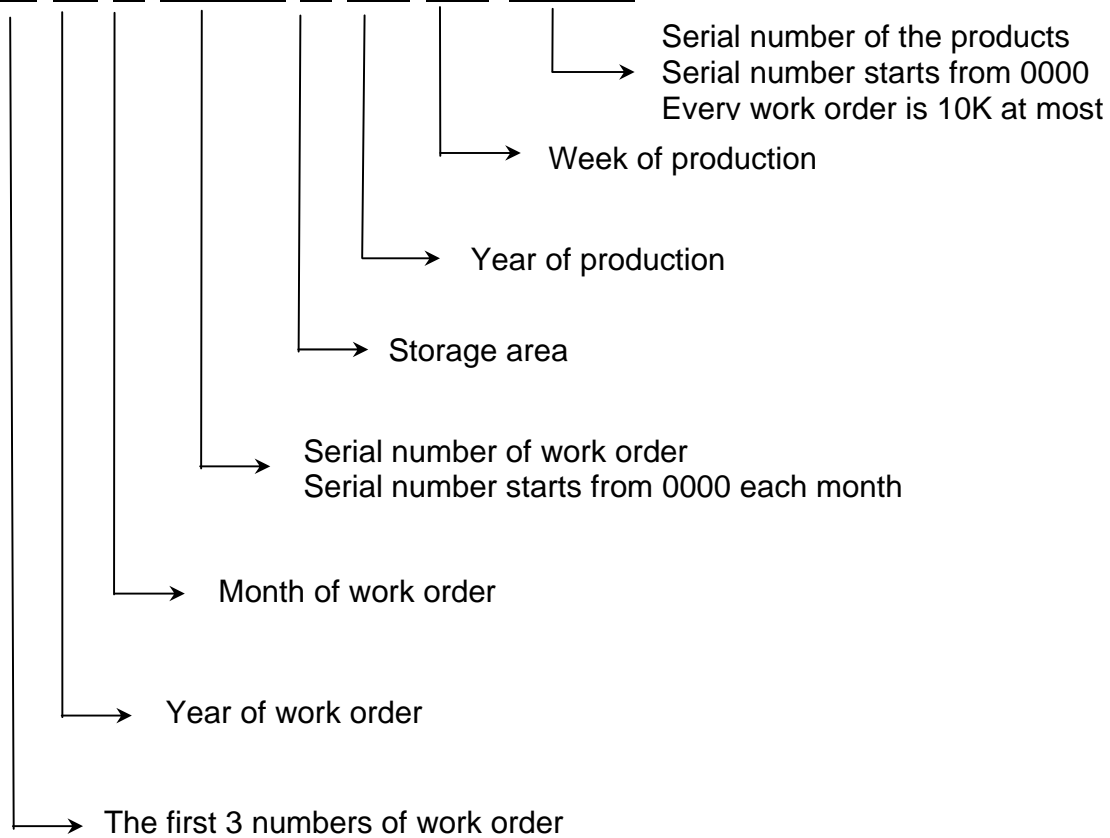

Product Name Define:

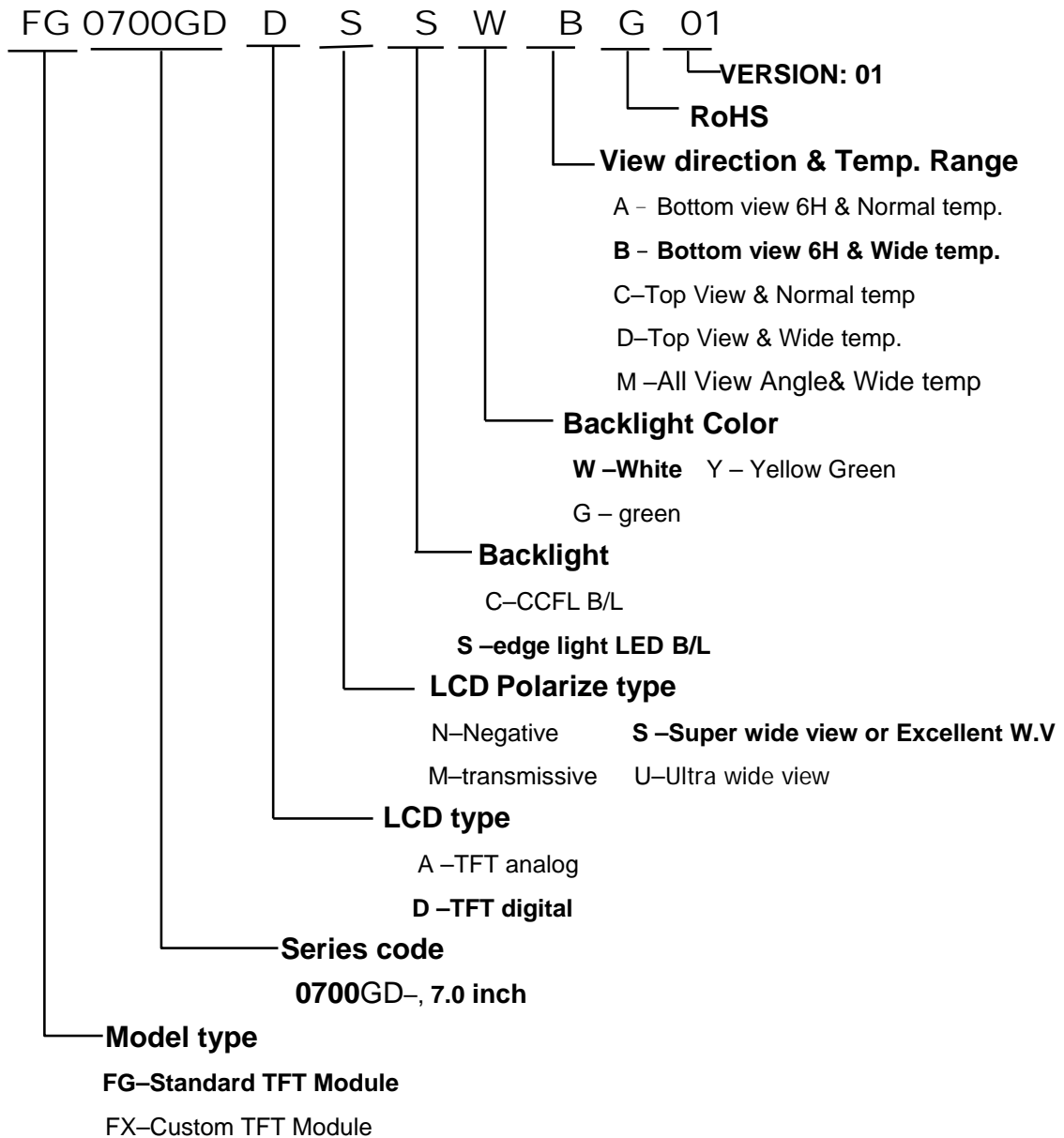

13. PRECAUTIONS IN USE LCM

1. ASSEMBLY PRECAUTIONS

- (1) You must mount a module using holes arranged in four corners or four sides.
- (2) You should consider the mounting structure so that uneven force (ex. Twisted stress) is not applied to the module. And the case on which a module is mounted should have sufficient strength so that external force is not transmitted directly to the module.
- (3) Do not touch, push or rub the exposed polarizers with glass, tweezers or anything harder than HB pencil lead. And please do not rub with dust clothes with chemical treatment.
- (4) Wipe off saliva or water drops as soon as possible. Their long time contact with polarizer causes deformations and color fading.
- (5) Do not open the case because inside circuits do not have sufficient strength.
- (6) Please do not take a LCD module to pieces and reconstruct it. Resolving and reconstructing modules may cause them not to work well.
- (7) Please do not touch metal frames with bare hands and soiled gloves. A color change of the metal frames can happen during a long preservation of soiled LCD modules.
- (8) Please pay attention to handling lead wire of backlight so that it is not tugged in connecting with inverter.

2. OPERATING PRECAUTIONS

- (1) Please be sure to turn off the power supply before connecting and disconnecting signal input cable.
- (2) Please do not change variable resistance settings in LCD module. They are adjusted to the most suitable value. If they are changed, it might happen LCD does not satisfy the characteristics specification
- (3) Be careful for condensation at sudden temperature change. Condensation makes damage to polarizer or electrical contacted parts. And after fading condensation, smear or spot will occur.
- (4) When fixed patterns are displayed for a long time, remnant image is likely to occur.
- (5) Module has high frequency circuits. Sufficient suppression to the electromagnetic interference shall be done by system manufacturers. Grounding and shielding methods may be important to minimize the interference.
- (6) Please consider that LCD backlight takes longer time to become stable of radiation characteristics in low temperature than in room temperature.

3. ELECTROSTATIC DISCHARGE CONTROL

- (1) The operator should be grounded whenever he/she comes into contact with the module. Never touch any of the conductive parts such the copper leads on the PCB and the interface terminals with any

parts of the human body.

- (2) The modules should be kept in antistatic bags or other containers resistant to static for storage.
 - (3) Only properly grounded soldering irons should be used.
 - (4) If an electric screwdriver is used, it should be well grounded and shielded from commutator sparks.
 - (5) The normal static prevention measures should be observed for work clothes and working benches; for the latter conductive (rubber) mat is recommended
 - (6) Since dry air is inductive to statics, a relative humidity of 50-60% is recommended.
- #### 4. STORAGE PRECAUTIONS
- (1) When you store LCDs for a long time, it is recommended to keep the temperature between 0°C-40°C without the exposure of sunlight and to keep the humidity less than 90%RH.
 - (2) Please do not leave the LCDs in the environment of high humidity and high temperature such as 60°C 90%RH
 - (3) Please do not leave the LCDs in the environment of low temperature; below -20°C.

5. OTHERS

- (1) A strong incident light into LCD panel might cause display characteristics' changing inferior because of polarizer film, color filter, and other materials becoming inferior. Please do not expose LCD module direct sunlight and strong UV rays
- (2) Please pay attention to a panel side of LCD module not to contact with other materials in preserving it alone.
- (3) For the packaging box, please pay attention to the followings:
- (4) Please do not pile them up more than 5 boxes. (They are not designed so.) And please do not turn over.
- (5) Please handle packaging box with care not to give them sudden shock and vibrations. And also please do not throw them up.
- (6) Packing box and inner case for LCDs are made of cardboard. So please pay attention not to get them wet. (Such like keeping them in high humidity or wet place can occur getting them wet.)

6. LIMITED WARRANTY

Unless otherwise agreed between DATA IMAGE and customer, DATA IMAGE will replace or repair any of its LCD and LCM which is found to be defective electrically and visually when inspected in accordance with DATA IMAGE acceptance standards, for a period on one year from date of shipment. Confirmation of such date shall be based on freight documents. The warranty liability of DATA IMAGE is limited to repair and/or replacement on the terms set forth above. DATA IMAGE will not responsible for any subsequent or consequential events.

Confidential Document
14. OUTLINE DRAWING

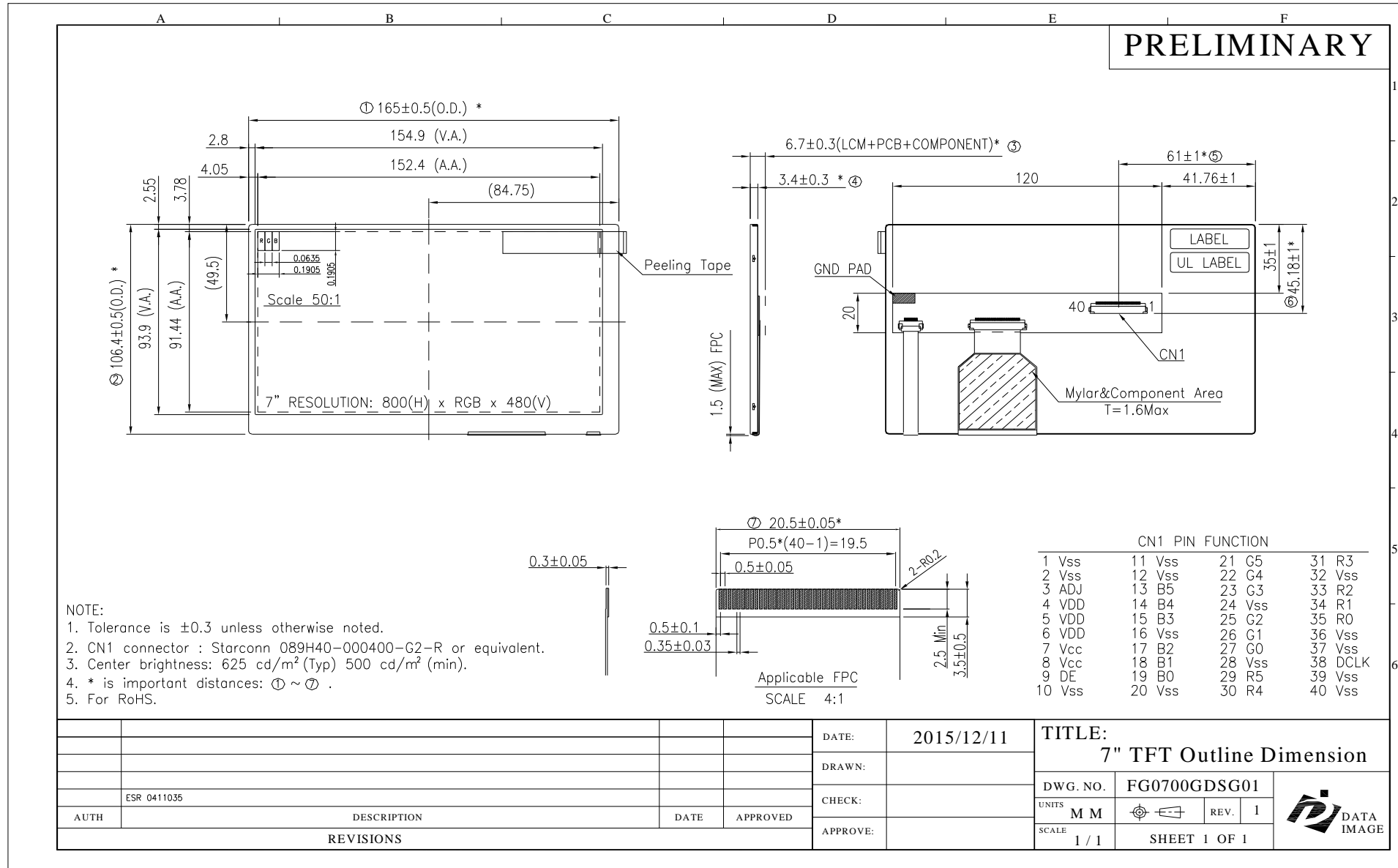

15. PACKAGE INFORMATION

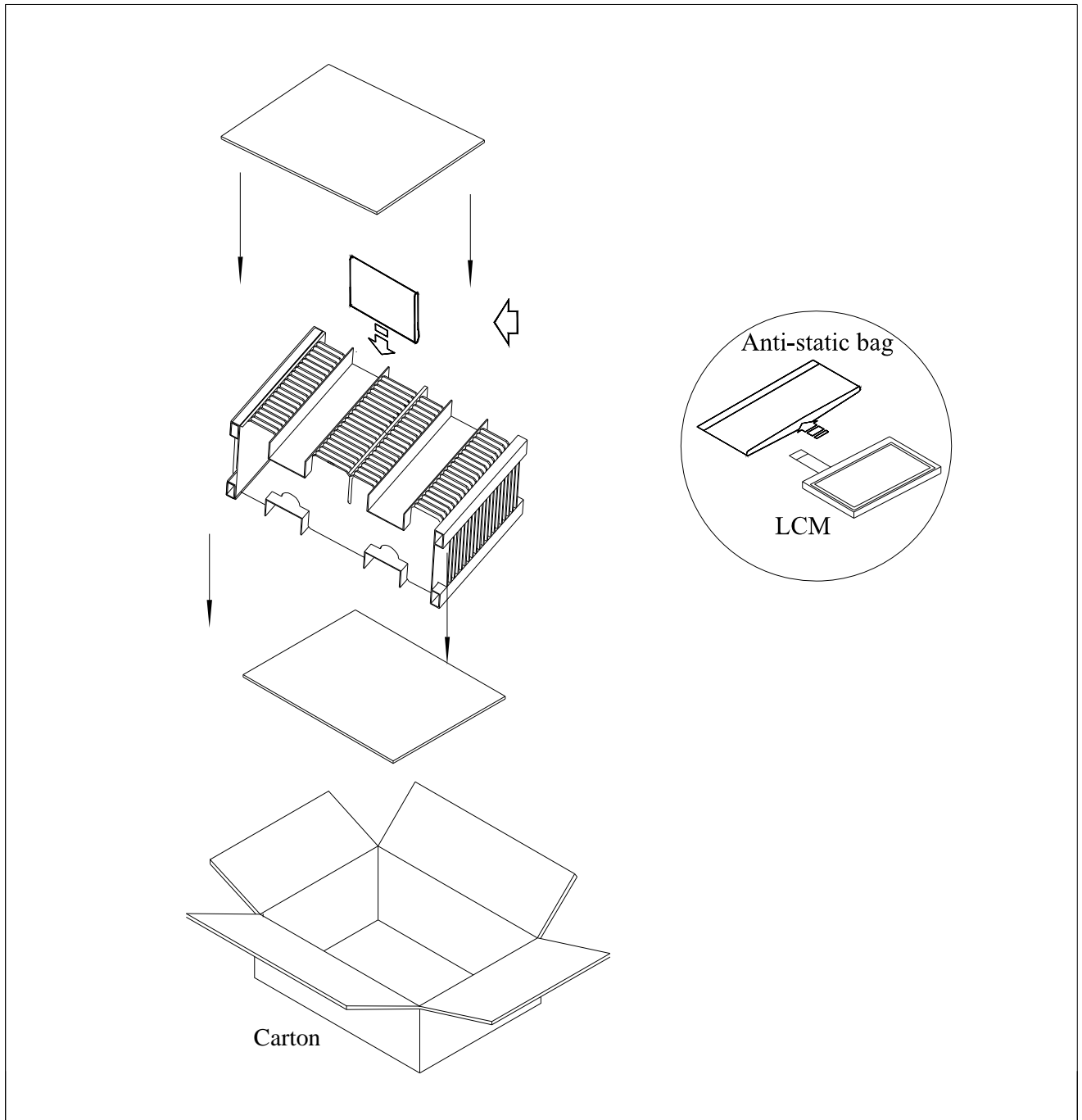

Item	Size(L*W*H)	Quantity	Note
Master Carton	482*282*279	1	
Quantity Per Master Carton		38	
N . W	7.0 (kg)	G . W	8.5 (kg)